

Presentation to NHS – HE Forum

National Video Conferencing Pilot in North of Scotland

Edinburgh 8th June 2010

Ron MacDonald

NISGTelecom

Video Conferencing in the NHS

- Supporting Telehealth - To improve the quality of services for patients. Local access to services.
- Professional education and development
- To improve access to Clinical expertise in rural areas,
- Produce Efficiency savings by reducing travel

Can we support this.....

Deficiencies with Video Conferencing in the NHS

- Piecemeal approach to procurement and implementation of services.
- Poor service particularly between NHSBoards
- Limited mostly to ISDN with poor video quality
- Difficult to use
- No central directory of VC devices.

National Video Conferencing Pilot

- Makes use of existing NHSBoard equipment.
- National Directory and Local conference booking
 - Populated from NHSBoard systems
 - Available on line
 - Hosted in Data Centre.
- National Video Gatekeeper Service
 - Routes Board A to Board B Video over N3.
- Local NHSBoard Support continues.
- Trial with NHSGrampian. Highland, Tayside, Western Isles, Orkney and Shetland

Migration from ISDN to IP (N3)



VC Trial - Objectives

1. To evaluate the Service pre-business case
2. Check compatibility and interoperability with existing VC equipment.
3. Compare performance of N3 with existing ISDN VC systems
 - Video and sound quality
 - reliability
4. Measure user experience
 - Ease of use
 - Controlled clinical bandwidth trials

Pilot - What would be provided

- A National Gatekeeper and Management System
 - Licences for around 300 devices
 - 1 year support of above equipment
 - Installation and testing
- Not in scope:
 - National MCU (or Bridging service)
 - Gateway (IP- ISDN)
 - Licences for Boards out-with trial (would not exclude anyone who wanted to register a VC device)

Testing to JANet

Video Conferencing Architecture - Now

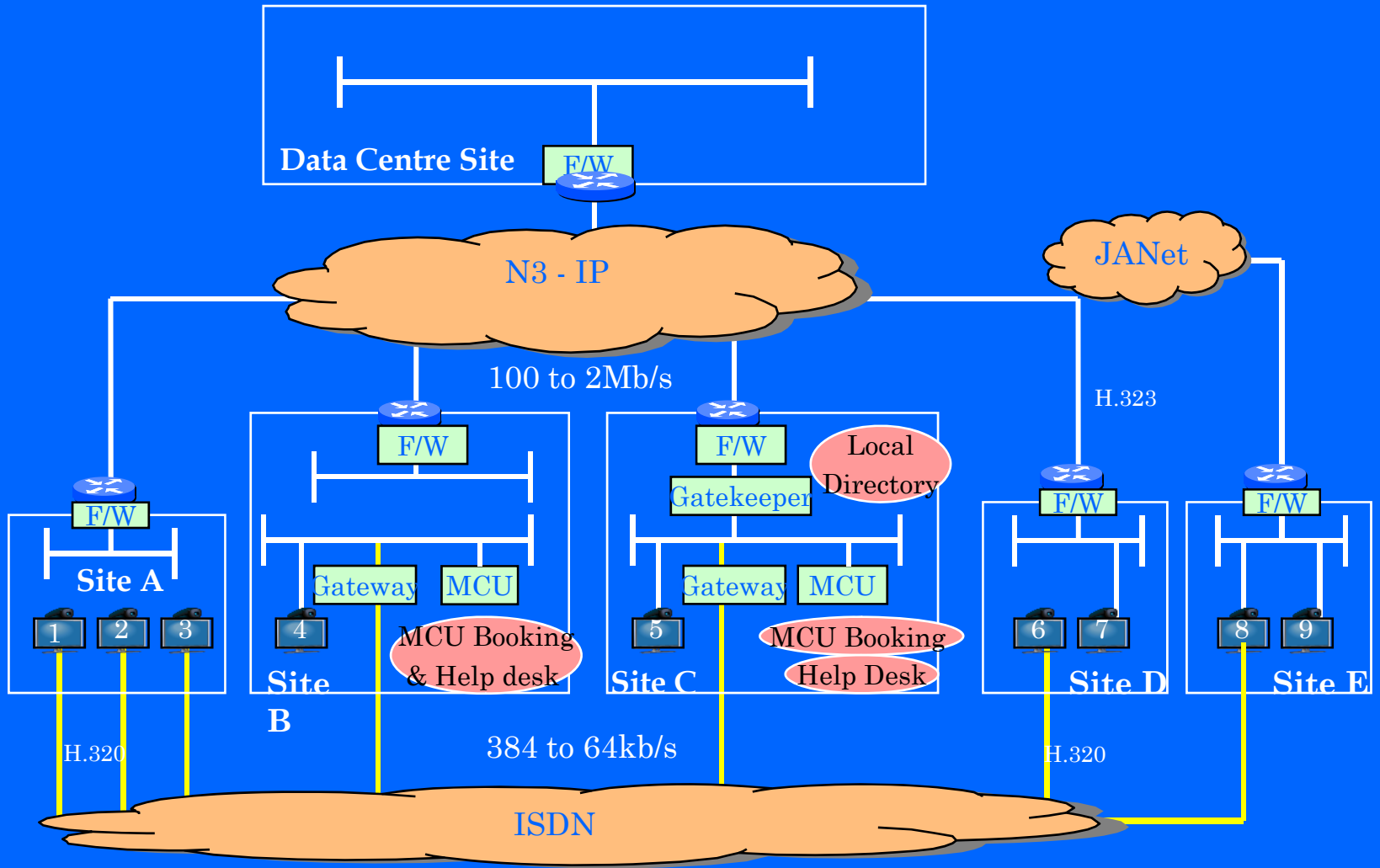

All sites connected to N3 but most use ISDN for Video

Video Conferencing Solution – Pilot

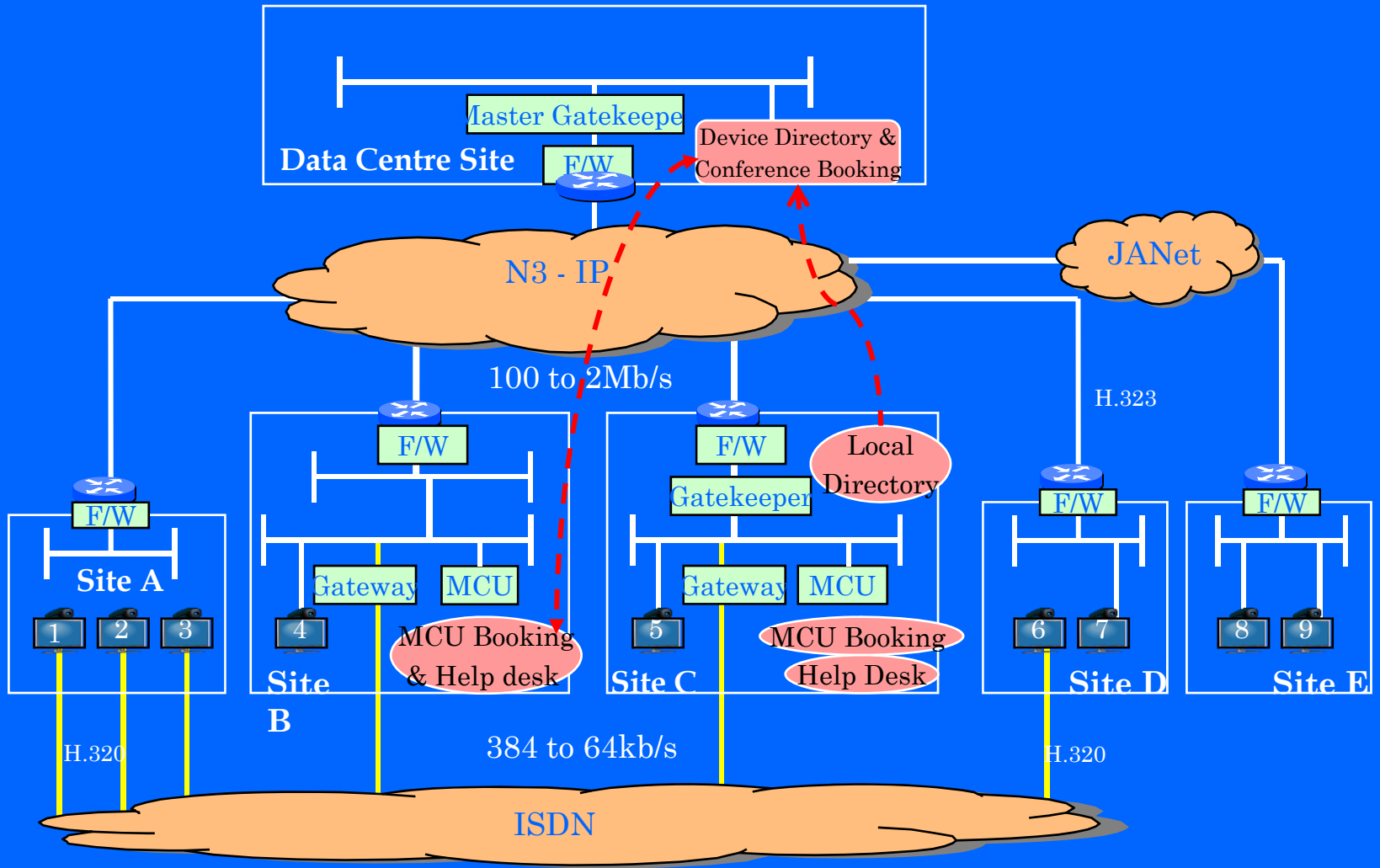

Gatekeeper and Management System + Local MCUs and Gateways

Issues

- Bandwidth
 - 512k pragmatic minimum
- Code of Connection
 - Agreement on need for standards
- Gatekeeper Architecture
 - Should be hierarchical.
- National Dial Plan
 - Different dial plans in place
 - Need to agree common standard, adopt JANET
- IPAddressing and Firewall settings
 - Good progress need to communicate with supporting documentation
- Management System
 - Must have the same system taking into account current estate.

Agreed Management System

- A Single Management service
 - Directory of Video devices
 - Booking and conference scheduling service
 - Performance status monitoring and reports
 - E-mail confirmation of booking to all attendees

Agreed Gatekeeper Architecture

- Hierarchy structure
- One National (NHSScotland) Gatekeeper
- Optional NHSboard Gatekeepers
- NHSBoards can register direct to National Gatekeeper
- Appropriate number plan to facilitate.

Gatekeeper Hierarchy – Pilot

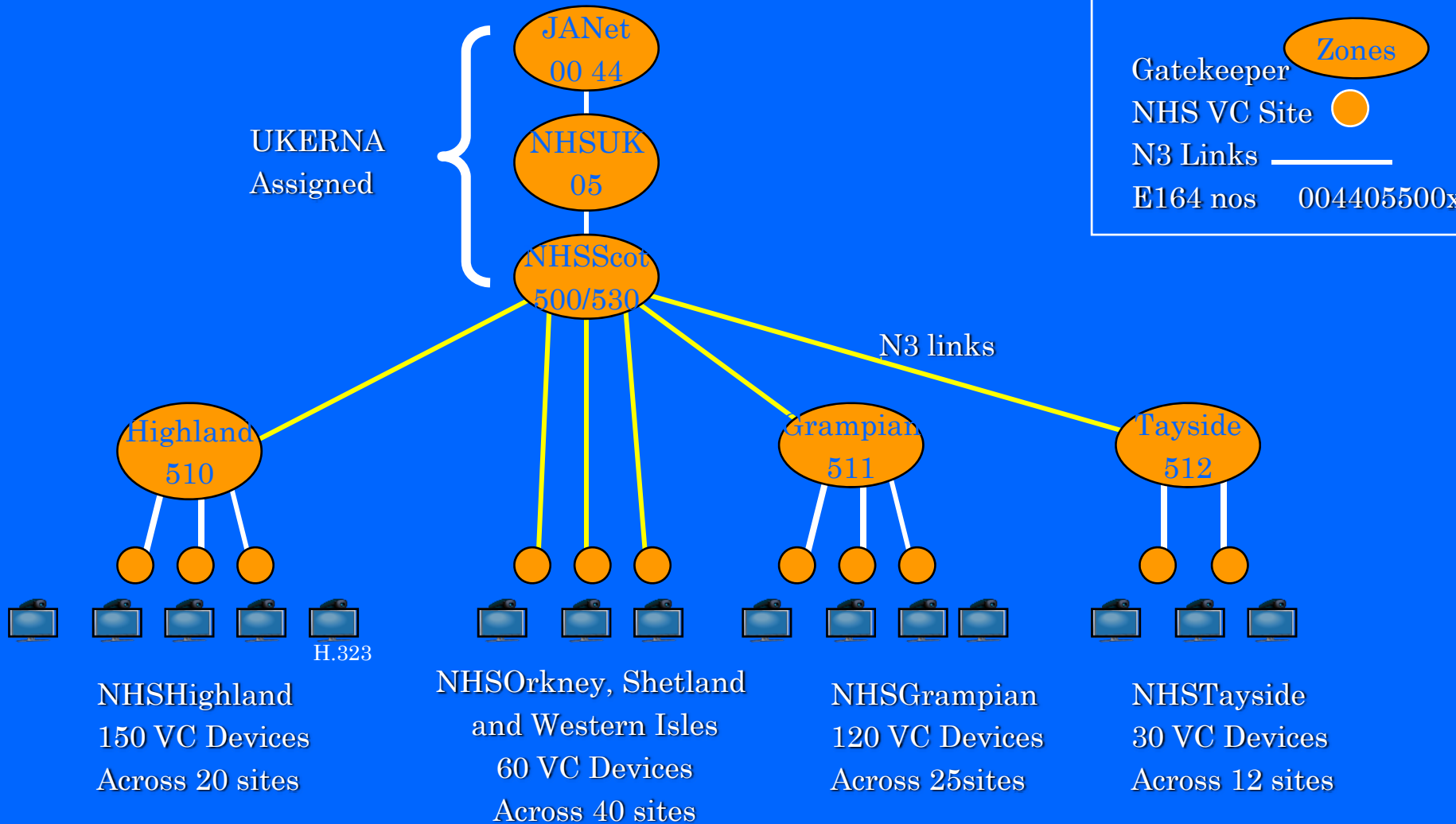

Direct Numbering to be agreed

VC Estate Bandwidth Analysis

	No of Devices	No of Sites	Sites > 10Mb/s	Devices on sites >10Mb/s
North of Scot	342	95	23.2%	47.1%
Non NOS	251	104	41.3%	72.5%
Total	593	199	32.7%	57.8%

Bandwidth affordability in rural areas is biggest barrier



VC Pilot - Progress

1. Draft Standards and naming conventions identified. Circulated to e-Health Infrastructure leads for comment.
2. JANET Confirm National numbers for NHSScotland Gatekeeper and agree testing plan.
3. 75% of sites with Video endpoints have IP address allocated, 50% configured.
4. First all IP Multi Conference VTAG meeting.
5. Procurement for Gatekeeper and Management System issued nearly complete.
6. National Gatekeeper live in six weeks from Contract Award

- *Any Questions?*